

PLAN VIEW

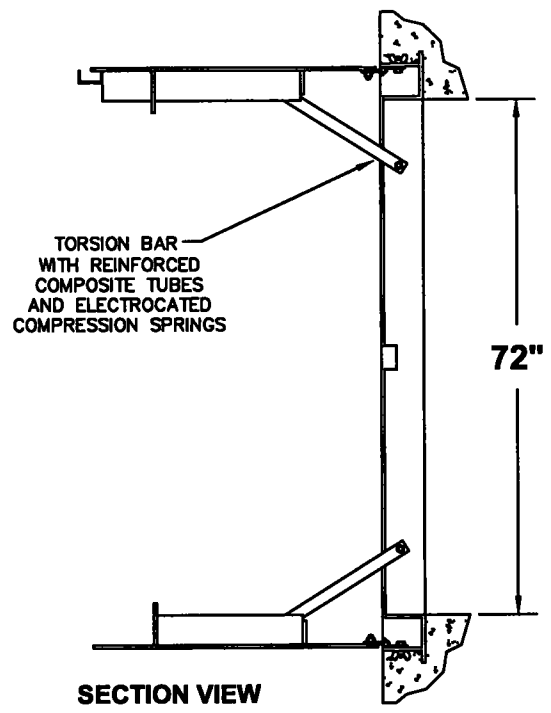

SECTION VIEW SIDE

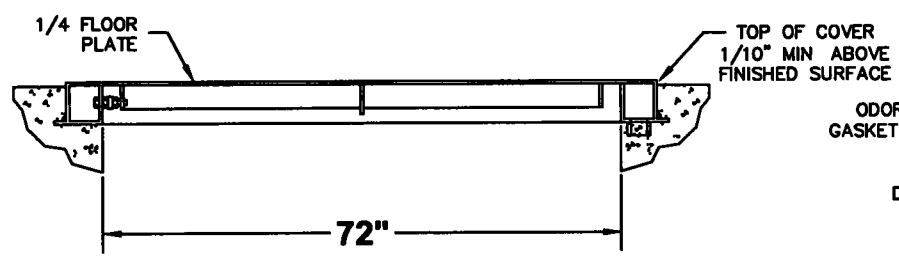

SECTION VIEW FRONT

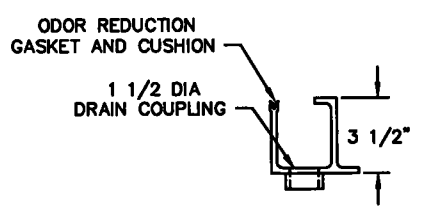

1/4 EXTRUDED TROUGH SECTION W/INTEGRAL CONT ANCHOR FLANGE AND GROOVES FOR GASKET/CUSHION  
 FRAME MAT'L ALUMINUM 6063-T5

FRAME DETAIL

NOTES

- 1- MATERIAL ALUMINUM
- 2- LOADING 300 LBS PER SQ FT
- 3- 316 STAINLESS STEEL BOLTS HINGES AND HOLD OPEN ARM
- 4- TORSION BAR WITH COMPRESSION SPRINGS

Weight 303 lbs (approx hatch base weight w/o options)

U S F FABRICATION  
 TPD 300 P S F

LAST DRAWING APPROVAL DATE	VISTA IRRIGATION DISTRICT	PATH Z ENGINEERING\TOMSTDDWGS\1-10A HATCH DWG
	PEDESTRIAN LOADING HATCH COVER FOR METER VAULTS	JOHN AMODEO DATE R C E 31161 <i>[Signature]</i> 9/25/02 STANDARD DRAWING 1-10 A